

HG-4008

Hydraulic Guillotine shears

Operation Manual

Serial No.: Q1306036

Contents

1、 Application of the Machine -----2

2、 Performance Parameters of Machine. -----3

3、 Structures of the Machine. ----- 4

4、 Hoisting and Installation----- 6

5、 Adjustment and Operation of Machine -----8

 5.1 Preparation before operation ----- 8

 5.2 Run trial ----- 8

 5.3 Single cut ----- 9

 5.4 Continuous cut ----- 9

 5.5 Adjustment of cutting angle ----- 9

 5.6 Reset of cutting angle ----- 40

 5.7 Fill oil ----- 10

6、 Hydraulic Driven System -----11

 6.1 Cutting principle ----- 11

 6.2 Valve position print ----- 11

 6.3 Valve action print ----- 12

7、 Electric System of Machine -----13

 7.1 General introduction ----- 13

 7.2 Caution ----- 13

 7.3 Electric principle chart----- 14

 7.4 Electric components list ----- 20

8、 Maintenance & Trouble Shooting -----22

 8.1 Blades ----- 22

 8.2 Lubrication of the machine----- 23

 8.3 Air pressure inspection of accumulator ----- 24

 8.4 Maintenance of hydraulic system ----- 24

 8.5 Maintenance of the machine ----- 25

9、 Packing List ----- 27

1. Application of the Machine

This machine suits the field of machinery, motors and electrics and light industry and etc. It is widely used in the straight cutting of various metal plates (with tensile strength less than $\sigma_b \leq 450\text{Mpa}$).With relatively small cut thickness and better knife, it can also cut the plates of low alloy steel, stainless steel, spring steel which is with strong tensile strength.

2、 Performance Parameters of Machine (table 1)

No.	Item		Data	Unit	Notes
1	Max. Cutting Thickness		8	mm	
2	Max. Cutting Width		4000		
3	Shear angle		2	Degree	
4	Stroke times without load		7	Min-1	
5	Upper knife Holder Maximum Travel		140	Mm	
6	Maximum Cutting Force		280	KN	Including the return pressure
7	Maximum Clamping Pressure		280	KN	Vary as per the load
8	Maximum Working Pressure of Hydraulic System		18	MPa	
9	Adjustment Range of Back-gauge		10-1000	mm	
10	Table Height Above Floor		800	mm	
11	Main Motor	Model	Y132M-4B5		
		Power	7.5	kw	
		Speed	1440	R/min	
12	Oil Pump	Model	NT3-G25F		
		Flow	25	ml/r	
		Pressure	31.5	Mpa	
13	Overall Dimensions	Length	4650	mm	
		Width	2350		
		Height	2100		
14	Machine Gross Weight		8500	kg	
15	oil capacity		330	L	

3、 Structure of the Machine

3.1 Frame: Welded steel construction with excellent rigidity and stability. The main parts consist of left and right support pillars, clamping board, a working table and oil tank. The two cylinders are mounted on the support board which connects the two support pillars and boards.

3.2 Upper knife beam: a triangle steel-sheet welded structure with guiding rail plate, blade and back-gauge device. The cutting operation is effected through reciprocation movement actuated by left and right cylinders.

3.3 Cylinders device on the left and right: It consists of two piston cylinders and sealing components. This device directly drives the movement of upper knife beam.

3.4 Hydraulic system: It consists of Main motor, oil pump, valve, oil tank, pipings and etc. It is the driving system of the machine.

3.5 Clamping device: Consists of many cylinders which are installed at the front of the machine frame. When oil enters the clamping cylinders, the clamping heads overcome the pull strength of the springs, press down, clamp the sheet to cut, then return to its original position with the help of spring force after cutting. The clamping strength increases as the plate thickness increases.

3.6 Blade gap adjustment device

It consists of adjustment handle, lever, dial and etc. The gap can be adjusted according to the plate thickness.

3.7 Electric system

It consists of electric box which is installed on the left support pillar and the buttons at the plate. This is for operation and control of the machine.

3. 7. 1 Panel fig of switchboard (chart 1)

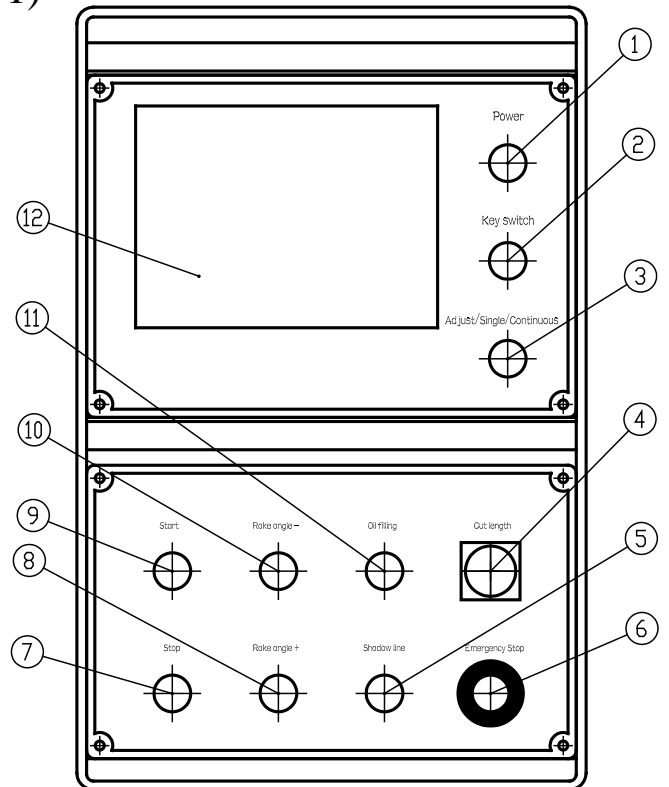

NO.	Function explanation
1	Power indicator
2	Power switch
3	Adjusting\single cutting\continuous cutting switch
4	cutting stroke adjustment
5	Daylight lamp
6	emergency stop
7	Main motor stop
8	Cutting angle increase
9	Main motor start
10	Cutting angle decrease
11	Oil filling button
12	NC89

4、Hoisting and Installation

4.1. Hoisting

4.1.1 The machine has lift holes at the top for hoisting . Pls choose proper steel ropes and hoisting equipment as per the machine weight. Accidents will occur if the hoisting is not effected properly.

4.1.2 The basis of the machine

The earth around the basis should be solid , and the depth depends on the specific condition.

4.1.2.1 Basis draw (chart2)

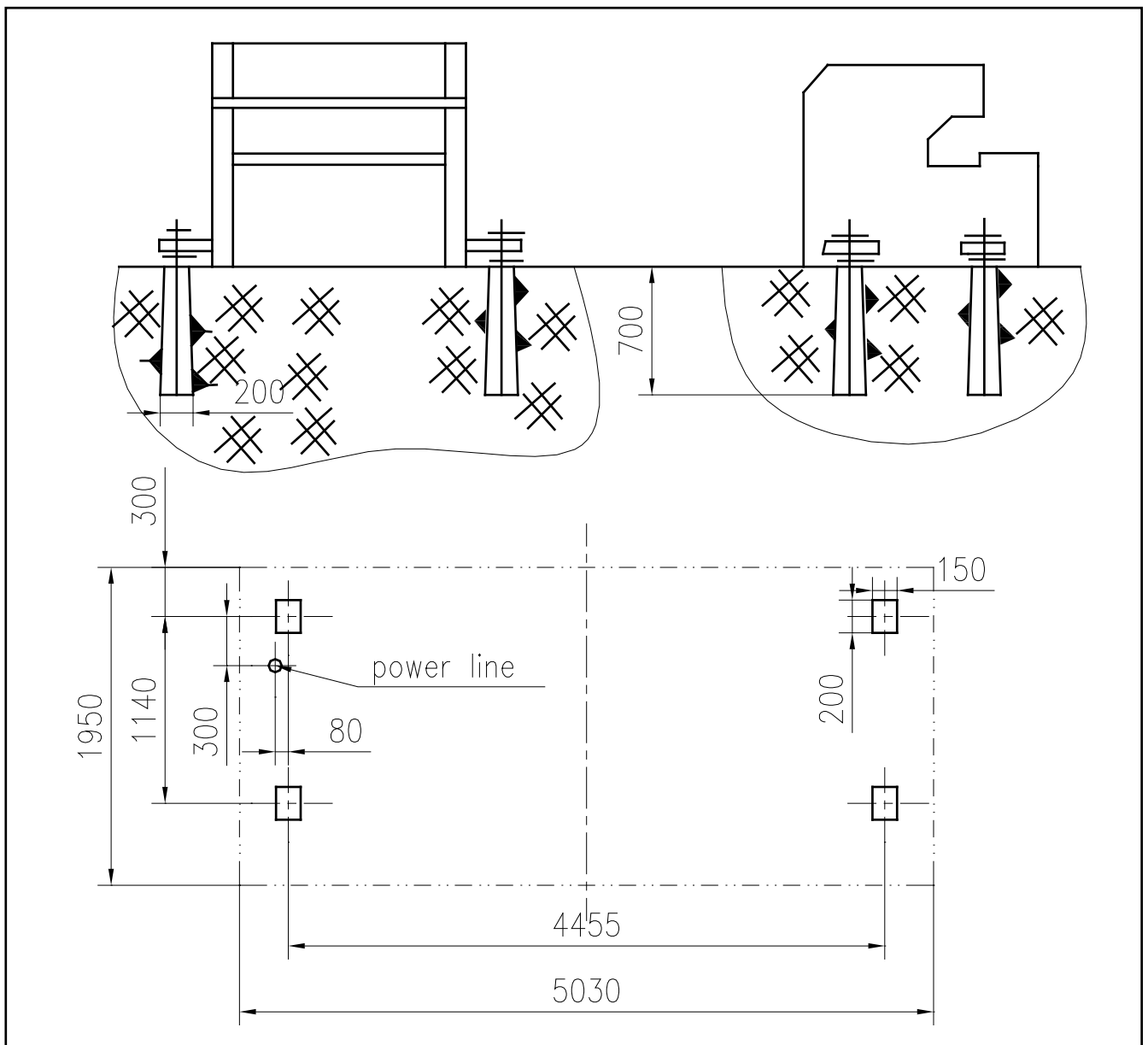

4. 2 Installation of the machine

4.2.1 When installation , remove the balling cover on the worktable , and put the same height pad at the processing side. And put the IM ruler on the pad. And then use the lever meter to adjust vertically and horizontally , the allowance is less than 0.2mm every 1000mm length, the left and right direction should be same. The base depth for machine installation depends on the earth situation (but not less than 500mm.) The earth pouring work is done by twice(pls see the chart). After 15 days from the date of first pouring,put the machine on the base and adjust horizontally and then set the foot screws and adjust the pad iron and then make the second pouring. After 48 hours of that, adjust horizontally and tighten the foot screws.

5、 Adjustment and Operation of the Machine

5.1 Preparation before the operation

- A、 Clean the oil stains of the machine surface, inspect all bolts are tighten.
- B、 Fill the lubrication grease .
- C、 Clean and fill the Model L-HL 46 ordinary hydraulic oil into the oil tank。
- D、 The machine should be grounded , connect the power supply , the machine uses 420V/50HZ power.
- E、 Tighten all hydraulic pipe connecting nut.
- F、 before the delivery of the machine, the various valves have been locked properly and tightly. Pls do not adjust the handwheel freely to avoid abnormal action of the machine and avoid loss.
- G、 the air pressure of accumulator has been setted to 5~6 MPa before delivery, need not to adjust unless you have special situation

5.2 Run Trial

- A、 Power on and turn the power switch to “1 ”.
- B、 Push the motor button , and start the main motor. Inspect the motor(use the same axis with oil pump) and make sure that the motor rotation direction should conform to the oil pump marked direction. If not conformed, pls change the input phase . But do not change the inner connection. When conformed, start main motor.
- C、 Because the knife beam is on the bottom dead point, pls reset it.
 - 1) Turn the switch on the penal to adjust function
 - 2) Press oil filling button and angle increase button meantime, adjust the filling pressure to 16~18 MPa and keep 2~3 seconds.

3) Loose the angle increase button first, then loose oil filling button, knife beam return.

4) Turn the switch on the penal to cutting function

D、 Turn the hand wheel according to the plate thickness and adjust the blade clearance

E、 Adjust the back gauge distance according to the plate length.

F、 After above action is finished, then Stamp the foot switch and start the cutting.

G、 Push the red button “EMERGENCY STOP” when machine is abnormal or when you want to stop the machine.

H、 After the machine is tested fine under both no load operation and load operation, then you can make the machine into formal production. If find the machine is abnormal, you will have to correct the problems and then put into production.

5.3 Single cutting

Turn the switch on the penal to single cutting mode, then stamp the foot switch, the knife beam moves down and starts to cut. The cutting is finished when moves to the lower limit SQ3 or when you release the foot switch. After complete the cutting stroke, the machine will automatically moves up until it is up to the upper limit SQ4 . If the plate is not cut off completely, pls do not release the foot switch to avoid the hurt of plate.

5.4 Continuous cutting

Turn the switch on the penal to Continuous cutting mode, stamp the foot switch and press the pump start button at the same time, then loose them, The knife beam will automatically repeat the action of single mode until that times are up or switch is turned off . Anyway we do not encourage customers to use this mode as the

machine runs quickly and sometimes may hurt the plate or accident occurs.

5.5 Adjustment of cutting angle

Turn the switch to adjust mode, press the angle decrease or increase button to decrease or increase cutting angle; after adjustment, turn the switch to cutting mode.

5.6 Reset of cutting angle(oil compensation of the series oil circuit)

The cutting angle is set up to be 2 degree originally. After many times angle adjustment, 2 degree maybe not obtainable, and in this situation the angle can be recovered back to 2 degree. (This item also suits the oil compensation of the series oil circuit). The procedure is as below: turn the switch to adjust mode, push the oil filling button , then push the angle increase button. When the knife beam moves down to the dead point, hold on the button for a few seconds and then release the angle increase button , then release the oil filling button . After adjustment is finished, turn the switch to cutting mode.

5.7 Oil filling

When the machine have been operated for a period of time, the return pressure may be consumed a lot, in this situation the knife beam can not return to the dead point, so we will have to fill the oil in this case. Oil filling procedures as below: turn the button on the panel to adjust mode, push the oil filling button, the knife beam moves down to the dead point, , adjust the overflow valve up to pressure around 16~18Mpa, the pressure will be displayed by pressure meter(17). When filling is finished, turn the button on the panel to cutting mode.

6、 Hydraulic Driven System

6.1 Cutting principle:

When stamp the foot switch, YV1 is electrified, the route to oil tank via overflow is closed. The output oil will enter into upper cavity of no. 12 cylinder , oil of the lower cavity of no.12 will enter into upper cavity of no.11 cylinder. The oil of lower cavity of no.11 cylinder will enter into accumulator 10, in this way it forms series route. The other route is: the oil enters into clamping cylinder 8 via ball valve 7. Then the clamping cylinder moves downward and hold down the plate. During the continuous increased oil pressure, the knife beam moves downward by overcoming the supporting force of lower cavity of no. 11 cylinder. And in this way the cutting action is achieved . At same time, the oil route working pressure is controlled by overflow valve 5. The pressure set up by manufacturer is 18 Mpa (nominal pressure). The pressure data will be readable from pressure meter 6. When the cutting is finished, The electromagnetic valve is power off, the oil from pump will return to oil tank via overflow valve 5. The knife beam returns back under the function of accumulator. , the clamping cylinder is returned by the spring force. Then the whole cutting performance is finished.

6.2、 valve position print(chart 3)

overflow valve(5)

main pressure meter(6)

electromagnetic valve for filling (14)

electromagnetic valve(4)

pressure meter for return(17)

electromagnetic valve for cutting

angle adjustment (9)

electromagnetic valve (16)

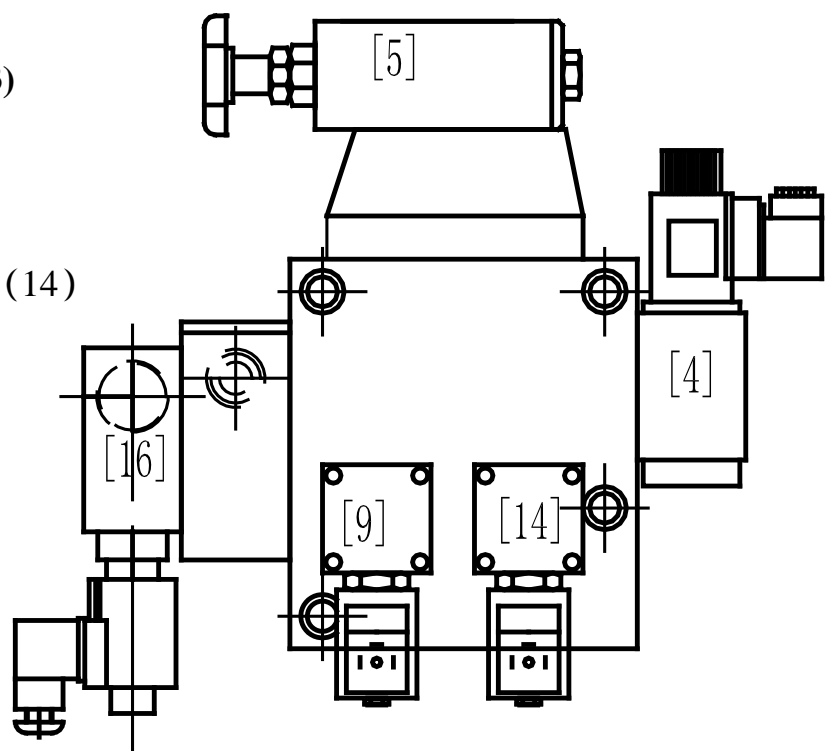

6.3 Hydraulic principle print(chart 4)

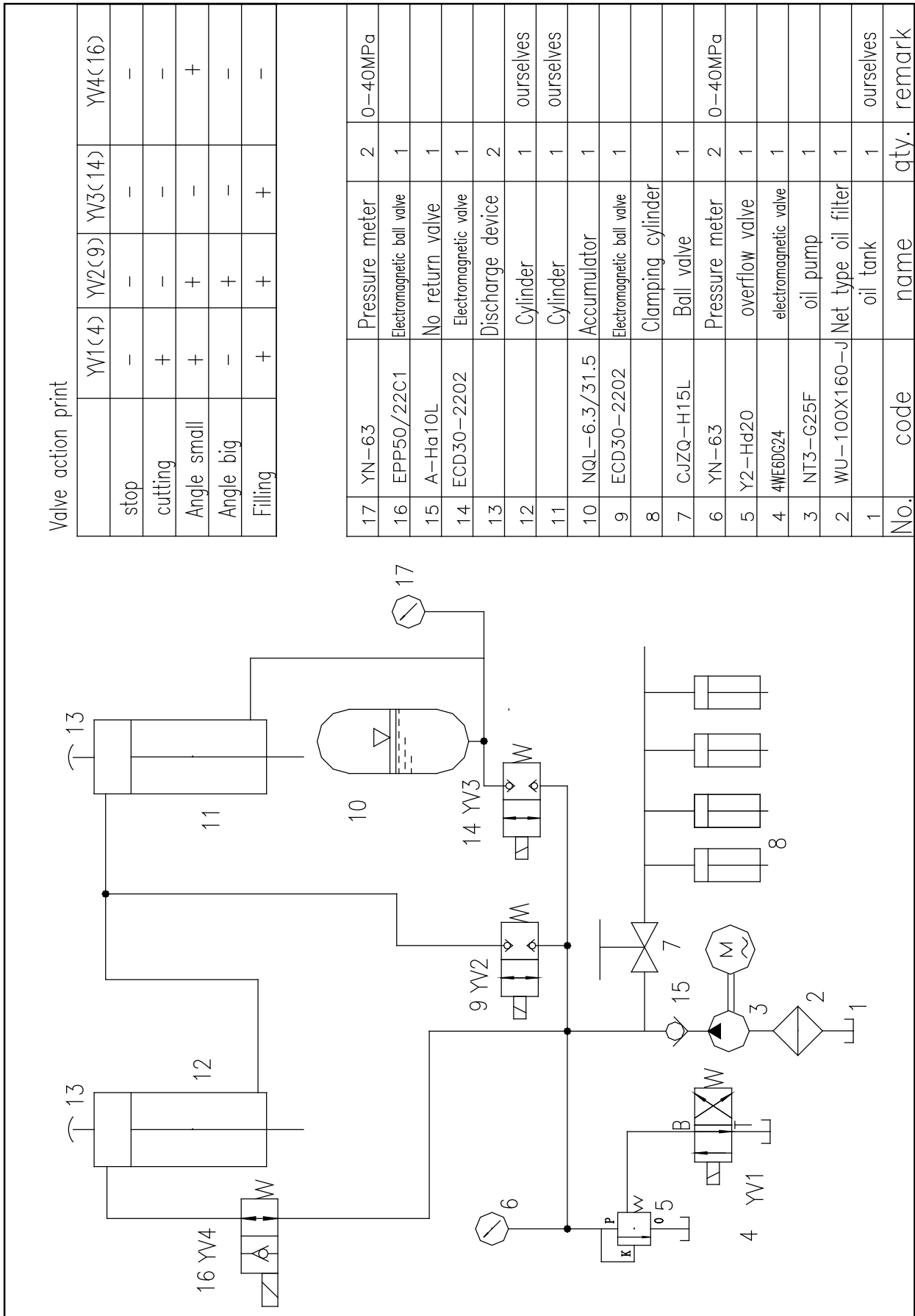

7、 Electric System of Machine

7.1 **General introduction:**

The machine adopts the three-phase 420V power supply. 24V to A.C. control circuit; 27V and then 24V to D.C. Light power is AC 220V; output of the transformer is supplied to control circuit. The machine connects the ground safely. The electric components of the machine are mainly installed inside the electric box and control panel. Pls refer to our electric components list for introduction of these components.

7.2 Caution:

7.2.1 This machine is special tool, so users should arrange special operators. The operators should read this operation manual very carefully and receive training by our plant. Operators can run this machine only under approval of our technicians by training. People without training can not run this machine to avoid loss and hurt.

7.2.2 Operator should lock the SA1 key button and turn off the power switch at the electric box when leaves . Make sure the machine is power off when no operator. The machine should be grounded properly.

7.3 Electric principle print(refer to chart 5)

7.4 Electric components list (refer to table 2)

power	air switch	main motor startup control	back gauga motor		fuse cox	transformer	
	earth terminal	mian motor thermal relay	forward	backward	alignment light switch	power supply:ac24v	confess system switch power

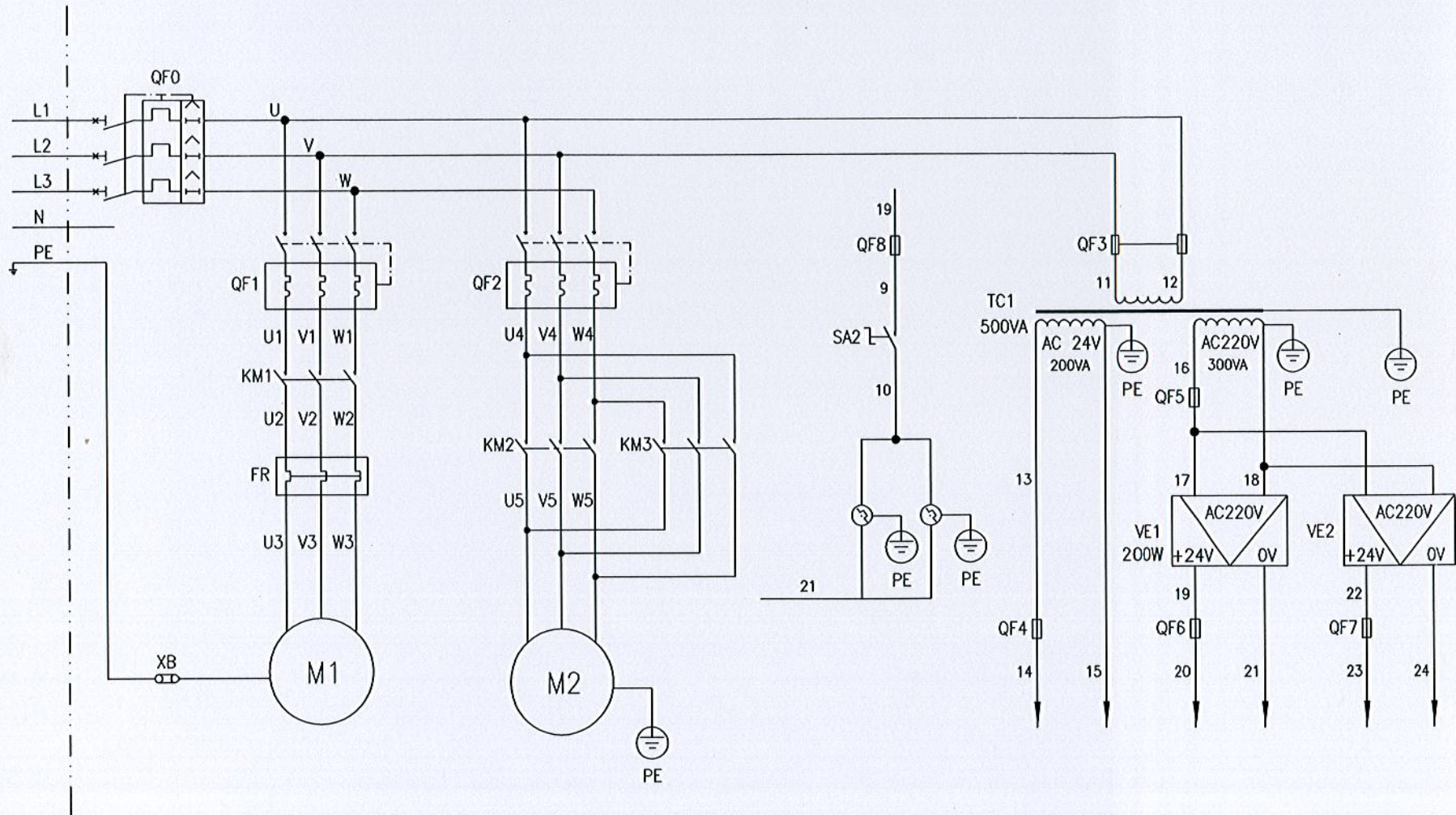

		key switch		oil pump start	pump running	back gauge motor control	
	daylight lamp switch	emergency stop	power indicator	oil pump stop	thermal relay	forward	backward

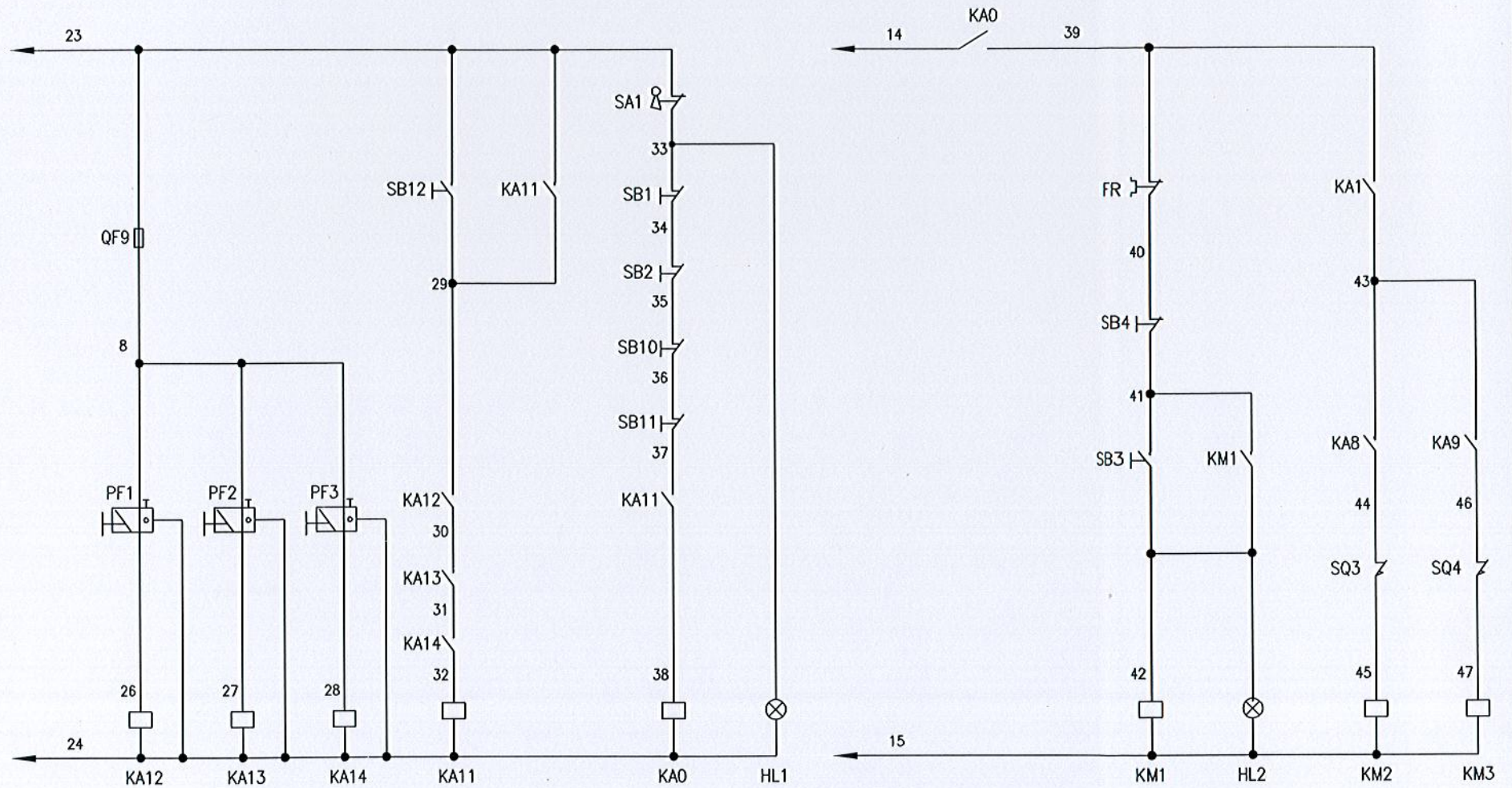

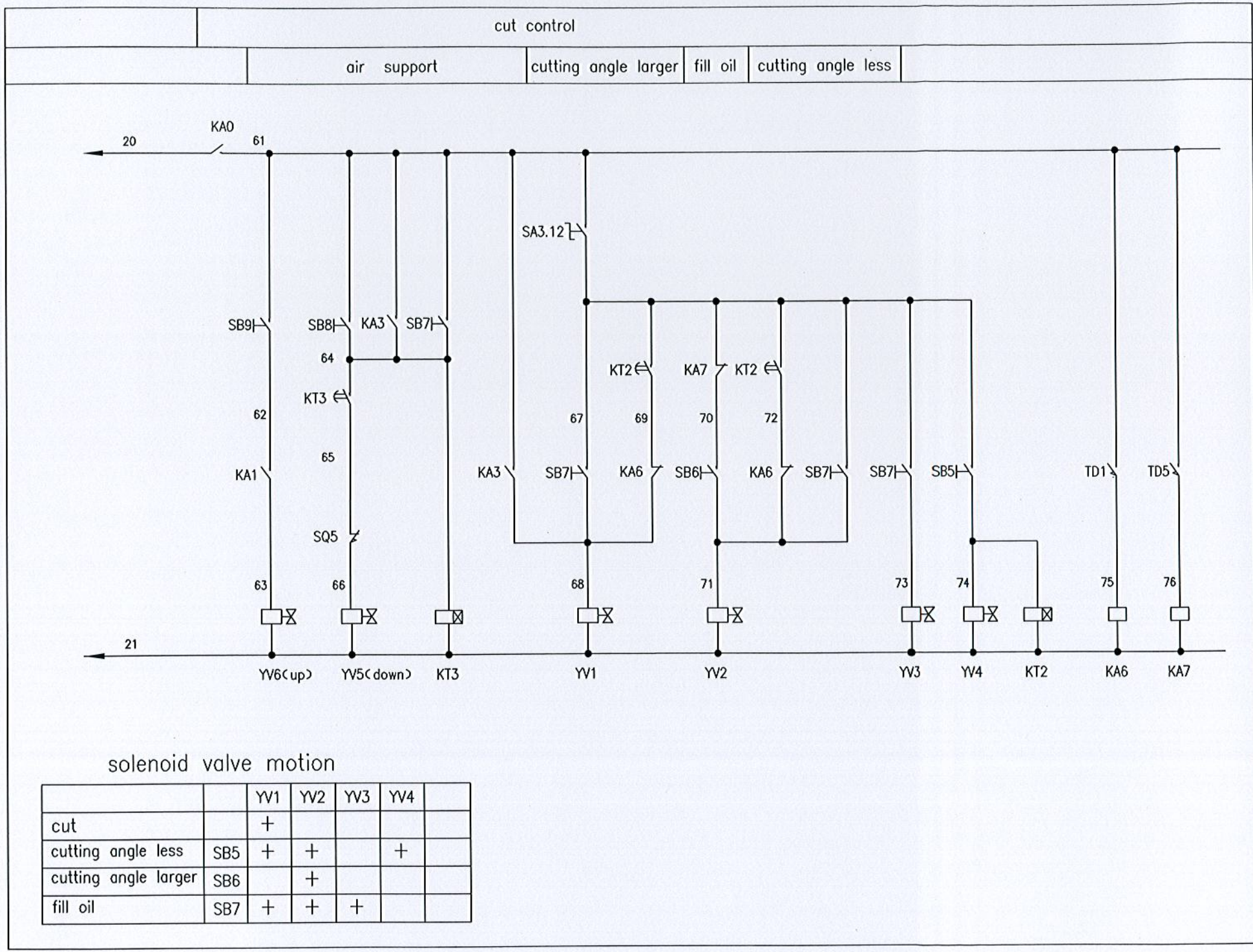

NC89W system control

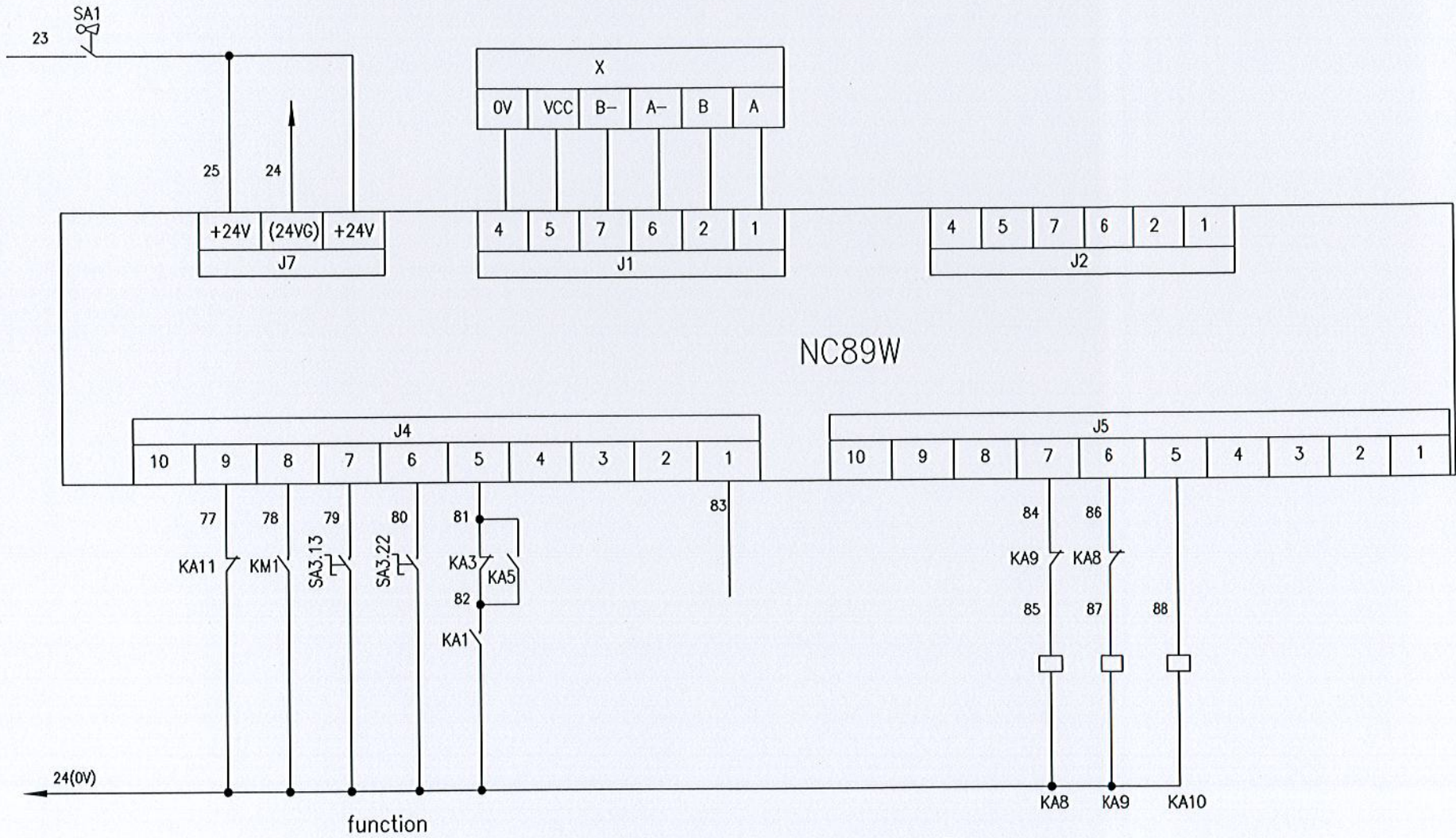

NC89W system control

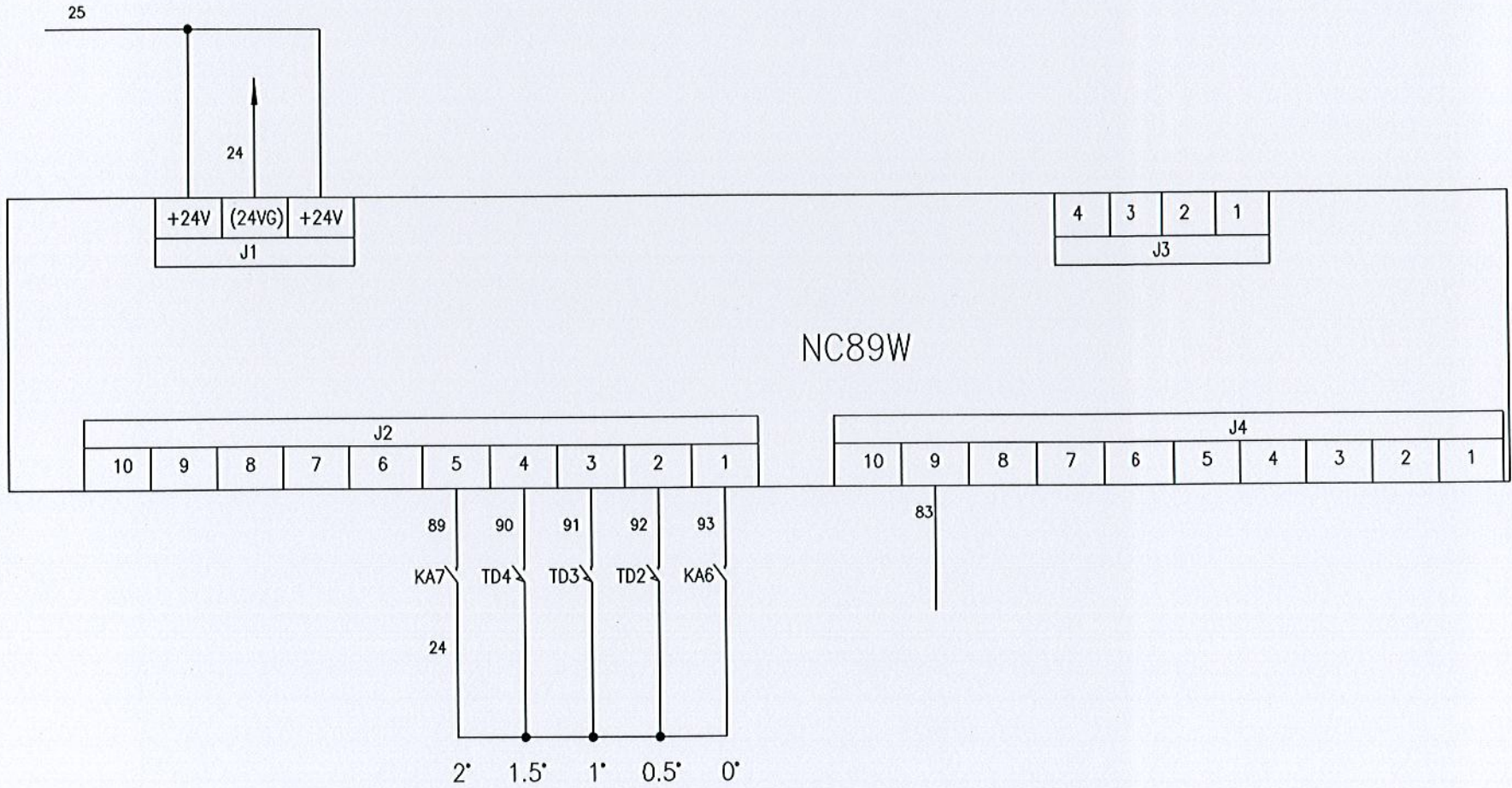

Electric components list(table 2)

SYMBOL	NAME	TYPE	QTY	REMARK
KM1	CONTACTOR	LC1-D2510B7	1	FOR MOTOR
KM2,KM3	CONTACTOR	LC1-D0910B7	2	BACK GAUGE MOTOR
FR	THERMAL OVERLOAD RELAY	LRD-13	1	FOR MOTOR
QF0	CIRCUIT-BREAKER	S1N100 32A	1	
QF1	CIRCUIT-BREAKER	C65N D32A/3P	1	FOR MOTOR
QF2	CIRCUIT-BREAKER	C65N D4A/3P	1	BACK GAUGE MOTOR
QF3	CIRCUIT-BREAKER	C65N C6A/2P	1	FOR CONTROL SYSTEM
QF4	CIRCUIT-BREAKER	C65N C6A/1P	1	AC24V POWER
QF5	CIRCUIT-BREAKER	C65N C6A/1P	1	FOR CONTROL SYSTEM
QF6	CIRCUIT-BREAKER	C65N C6A/1P	1	FOR VALVE
QF7	CIRCUIT-BREAKER	C65N C6A/1P	1	FOR SYSTEM
QF8	CIRCUIT-BREAKER	C65N C1A/1P	1	FOR LAMP
QF9	CIRCUIT-BREAKER	C65N C1A/1P	1	PHOTO SENSOR
KA0-KA1 2	RELAY	RXM4LB2B7	13	FOR CONTROL SYSTEM
SB5,SB6	BUTTON	XB2BA21C	2	FOR CUTTING ANGER
SA2	BUTTON	XB2BD21C	1	FOR LAMP
SA3	BUTTON	XB2BG33C	1	FOR CONTROL SYSTEM
SA1	BUTTON	XB2BG21C	1	FOR CONTROL SYSTEM

Hydraulic Guillotine Shear

SB1,SB2,S B10,SB11	BUTTON	XB2BT42C	4	EMERGENCY STOP
SB4	BUTTON	XB2BW33B1C	1	FOR MOTOR STOP
SB3+HL2	BUTTON	XB2BA42C	1	FOR MOTOR START
SB7	BUTTON	XB2BA31C	1	FILL OIL
SB8,SB9	BUTTON	XB2BA31C	2	AIR SUPPORT
HL1	LAMP	XB2BVB1C	1	FOR POWER SUPPLY
KT1	TIMER RELAY	H3CR-A8	1	CUTTING LENGTH
KT2	TIMER RELAY	ST3PA-Y	1	ADJUSTIVE
VE1	POWER SUPPLY	S-145-24	1	FOR VALVE
VE2	POWER SUPPLY	S-35-24	1	FOR CONTROL SYSTEM
TC1	TRANSFORMER	JBK5-500VA	1	
	CONTROL SYSTEM	NC89	1	
PF1-PF3		BEN100M-TFR	3	PHOTO SENSOR

8、 Maintenance & Trouble Shooting

8.1 Blades

8.1.1 The blade clearance (blade gap) adjustment:

It is a very important factor to adjust the blade clearance which relates the cutting quality and knife life. Pls follow below procedures: the clearance data is 0.07~0.10 times of the plate thickness, the plate thickness =0.07~0.10 t. The above is for specific elongation $\delta = 0.21$. For more than 0.21, it is suggested to use smaller clearance. And for less than 0.21, pls use larger clearance. Turn the handwheel in the front of the plane board to adjust the clearance data. That means adjust the clearance according to the plate thickness. The data will be displayed on the handwheel

8.1.2 measuring of blade clearance and adjustment of the proportional clearance

the proportional clearance relates the cutting quality directly. It is set up by the manufacturing and unnecessary to modify normally. After the machine has been used for a period of time and if the knife side is changed, then it is a must to adjust the blade clearance again . The adjustment procedure is as below: turn the switch to adjust mode, adjust knife beam to balance(cutting angle is 0, Turn the clearance adjust hand wheel anticlockwise to the “smallest clearance”, turn off main motor(power on), press oil filling button, move knife beam down until distance between upper and bottom blades is 3~5mm, adjust the bolts and nut which support bottom blade on work table, use the plug gauge to inspect the clearance. After the adjustment is finished, repeat reset course of knife beam(5.2.C).

8.1.3 The installation of the blade

After the machine has been used for a period of time, must turn over the blade sides or change the blade. The installation of the upper blade is as below: make the upper knife beam flat(the cutting angle is 0). Then turn off the screw at the lower knife to change the blade or turn over the blade. (be careful of the sharp blade to avoid hurt.) it is easier to change the lower blade. Just take off the upper blade cover at the working table and turn off the screw to change the blade or turn over the blade.

8.1.4 The grinding and change of the blades

The blades need to be ground timely. And It is costly if do not grind the blades timely. If the blade is not sharp enough, the blade will be hurt due to too much pressure in cutting and the cutting quality will be affected. So pls make up a complete blade grinding timeline according to the production status. It is recommended to have some spare blades for replacement at any time.

Our recommended blade grinding timeline:

- (1) For operation 80-100hours, pls turn over the blade sides. The upper blades and the lower blades can be turned over three times.
- (2) For operation 320-400 hours, pls grind the blade. For most severe damaged blade, pls change the blade. After the blade grinding or when new blade is used, the blade clearance needs to be reinspected and readjusted.

8.2 Lubrication of the machine

Good lubrication is a must for the proper machine operation and long machine life. Pls make good lubrication as per our provided procedures.

The main areas for lubrication:

- A、 The guiding rod and thread rod of the back gauge. Lubricate it once a week.
(clean the thread rod off the dirt and oil stains.)
- B、 3 rolled guiding rails. Lubricate it every day for the initial stage of machine running.
- C、 For the spare parts outside and the rolled bearings, pls lubricate it twice a week.

And pls inspect and clean the lubrication system frequently and take good care of them.

8.3 The air pressure inspection of accumulator(the air pressure has been setted to 5~6 MPa before delivery, need not to adjust unless you have special situation) When the upper knife beam returns slowly(the oil pressure is proper), pls inspect the air pressure of accumulator. The inspection way is as below: Make the machine power on, and do not start the main motor, turn the switch to adjust mode and push the oil filling button, discharge the return oil pressure and then the upper knife beam will move down to the dead center. Inspect the nitrogen pressure by accumulator nitrogen tool. If the nitrogen pressure is less than 5~6 Mpa, pls fill in. After inspection and the filling, pls follow up the oil filling procedures (5.7)

CAUTION: ONLY FILL IN THE NITROGEN INSIDE THE ACCUMULATOR, OTHERS ARE STRICTLY PROHIBITTED

8.4 The maintenance of the hydraulic system

8.4.1 The return lines(return circuit) of hydraulic system

- 1) check the oil level of the oil tank. If the oil level is less than the middle line, pls fill in the oil immediately up to the middle line.
- 2) After the machine has been run for one month, pls change the oil for the first time.
- 3) Pls change the oil every 2000 hours of operation.
- 4) The hydraulic oil should be qualified and the viscosity is 27-33.
- 5) Pls clean the oil tank thoroughly for every oil changing

8.4.2 Oil filter

- 1) Use gasoline or other solution to clean the oil filter. Pls refer to below timeline to clean the filter: Clean the filter first time after 8 days of machine formal operation. And later clean the filter every 30 days of operation.
- 2) Pls change the components of filter if they are found to be damaged.

8. 4. 3 Air filter

- 1) The air filter is installed at the oil tank.
- 2) Pls clean the filter first time after 500 hours of machine formal operation. Use gasoline or chloroethylene or other solution to clean it. And clean the filter every 1000 hours of operation.

8. 4. 4 Hydraulic pump

Pls refer to relevant technical data of hydraulic pump.

8. 4. 5 The inspection of the mechanical parts:

Pls check the fittings once a week for the tightness and also check the lubrication situation. If find any abnormal things, pls correct it immediately before operation.

8. 4. 6 Adjustment of safety overflow valve

The overflow adjustment is very important for normal operation of the machine. Pls adjust it as per the maximum working pressure. If it is found that the machine is damaged due to that the pressure adjusted data exceeds the maximum data, the manufacturer will not be responsible for this kind of problems or loss occurred due to incorrect adjustment.

8.5 The Maitenance of the Machine

- 1). Operator should be familiar with the construction and characteristics of the machine .The machine is operated by several operators simultaneously , so should arrange special person to be in charge of the production .
- 2). Never put the hand within the upper and lower blades to avoid hurt.
- 3). To prevent accident due to tools and dirty things between knives , there're should no tools and dirty things on the worktable .
- 4). You should period check the sharpness of knives , if they become blunt ,you should grind or change at once . To grind the knives you should only grind the thickness and ensure the thickness of one set knife are same .
- 5). You should period check each part of machine , maintain the cleanness of the machine and surround environment and the good insulation of wire .

6. To maintain filter in good condition , you should often check and clean the filter mounted on the suction port of pump . If the filter not in good condition , it will effect the life of pump .
- 7 **Only fill in the nitrogen inside the nitrogen bag of accumulator.(oxygen is prohibited strictly0)**. Pls fill in the nitrogen slowly to avoid t he breaking of the bag.
8. To avoid oil leakage, pls tighten the screws at the piping connection after 25 hours of operation initially. Pls tighten the screws again every 200 hours after formal production.

9、 Packing List

No	Item	Specification	quantity
1	Foundation Bolt	M20X500	4
2	Manual oil gun	Oil supply 1 cubic mm	1
3	Nitrogen fill tool		1
4	Operation manual		1
5	Quality Certificate		1
6	Foot switch	YDT1-12	1
7	Spanner		1
8	O-Ring	16X2.4	2
9	O-Ring	30X3.1	2
10	O-Ring	35X3.1	2
11	O-Ring	40X3.1	2
12	O-Ring	50X3.1	2
13	O-Ring	32X3.5	5
14	O-Ring	45X3.1	5
15	Pad	14	5
16	Pad	27	5
17	Pad	33	5
18	ferrule	10	5
19	ferrule	22	5
20	ferrule	28	5

WARNING

General Machinery Safety Instructions

Machinery House
requires you to read this entire Manual before using this machine.

- 1. Read the entire Manual before starting machinery.** Machinery may cause serious injury if not correctly used.
- 2. Always use correct hearing protection when operating machinery.** Machinery noise may cause permanent hearing damage.
- 3. Machinery must never be used when tired, or under the influence of drugs or alcohol.** When running machinery you must be alert at all times.
- 4. Wear correct Clothing.** At all times remove all loose clothing, necklaces, rings, jewelry, etc. Long hair must be contained in a hair net. Non-slip protective footwear must be worn.
- 5. Always wear correct respirators around fumes or dust when operating machinery.** Machinery fumes & dust can cause serious respiratory illness. Dust extractors must be used where applicable.
- 6. Always wear correct safety glasses.** When machining you must use the correct eye protection to prevent injuring your eyes.
- 7. Keep work clean and make sure you have good lighting.** Cluttered and dark shadows may cause accidents.
- 8. Personnel must be properly trained or well supervised when operating machinery.** Make sure you have clear and safe understanding of the machine you are operating.
- 9. Keep children and visitors away.** Make sure children and visitors are at a safe distance for you work area.
- 10. Keep your workshop childproof.** Use padlocks, Turn off master power switches and remove start switch keys.
- 11. Never leave machine unattended.** Turn power off and wait till machine has come to a complete stop before leaving the machine unattended.
- 12. Make a safe working environment.** Do not use machine in a damp, wet area, or where flammable or noxious fumes may exist.
- 13. Disconnect main power before service machine.** Make sure power switch is in the off position before re-connecting.
- 14. Use correct amperage extension cords.** Undersized extension cords overheat and lose power. Replace extension cords if they become damaged.
- 15. Keep machine well maintained.** Keep blades sharp and clean for best and safest performance. Follow instructions when lubricating and changing accessories.
- 16. Keep machine well guarded.** Make sure guards on machine are in place and are all working correctly.
- 17. Do not overreach.** Keep proper footing and balance at all times.
- 18. Secure workpiece.** Use clamps or a vice to hold the workpiece where practical. Keeping the workpiece secure will free up your hand to operate the machine and will protect hand from injury.
- 19. Check machine over before operating.** Check machine for damaged parts, loose bolts, Keys and wrenches left on machine and any other conditions that may effect the machines operation. Repair and replace damaged parts.
- 20. Use recommended accessories.** Refer to instruction manual or ask correct service officer when using accessories. The use of improper accessories may cause the risk of injury.
- 21. Do not force machinery.** Work at the speed and capacity at which the machine or accessory was designed.
- 22. Use correct lifting practice.** Always use the correct lifting methods when using machinery. Incorrect lifting methods can cause serious injury.
- 23. Lock mobile bases.** Make sure any mobile bases are locked before using machine.
- 24. Allergic reactions.** Certain metal shavings and cutting fluids may cause an allergic reaction in people and animals, especially when cutting as the fumes can be inhaled. Make sure you know what type of metal and cutting fluid you will be exposed to and how to avoid contamination.
- 25. Call for help.** If at any time you experience difficulties, stop the machine and call you nearest branch service department for help.

WARNING

Power Operated Guillotine Safety Instructions

Machinery House
requires you to read this entire Manual before using this machine.

- 1. Maintenance.** Make sure the Guillotine is turned off and disconnect from the main power supply and make sure all moving parts have come to a complete stop before any inspection, adjustment or maintenance is carried out.
- 2. Guillotine Condition.** Guillotine must be maintained for a proper working condition. Never operate a Guillotine that has low oil levels, damaged or worn parts. Scheduled routine maintenance should be performed on a scheduled basis.
- 3. Blade Condition.** Never operate a Guillotine with a damaged or badly worn blades. Replace if required.
- 4. Pump Direction.** Pump rotation must be in arrow direction otherwise the pump will be damaged.
- 5. Hand Hazard.** Keep hands and fingers clear from moving parts. Serious injury can occur if hand or finger tips come between blades.
- 6. Personal Protection.** Gloves are recommended when handling the workpieces.
- 7. Authorized and trained personnel.** The machine must be operated by authorized and trained personnel. The shear is designed to be operated by a single user. Using the machine with more than one operator is forbidden, except for certain maintenance situations.
- 8. Power outage.** In the event of a power failure during use of the machine, turn off all switches to avoid possible sudden start up once power is restored.
- 9. Work area hazards.** Keep the area around the Guillotine clean from oil, tools, objects & chips. Pay attention to other persons in the area and know what is going on around the area to ensure unintended accidents.
- 10. Guards.** Do not operate Guillotine without the correct guards in place. Necessary guards protect you from injuries by the shear blades.
- 11. Material.** Material must NOT be hardened ceramic or glass-originated, non flat metals (at origin) e.g. rods, bars, tubes & pipes.
- 12. Blade gap adjustment.** Do NOT operate the machine without proper blade gap adjustment according to sheet thickness.
- 13. Warning Labels.** Take note of any warning labels on the machine and do not remove them.
- 14. Backgauge Area.** Do not access the backgauge area, while the machine is working.
- 15. Protective fence.** Do not bridge the safety limit switch of the rear protective fence.
- 16. Squaring arm.** Do not use side squaring arm and front support arms for intermediate storage of workpieces.
- 17. Operation.** During the shearing process, the workpiece may slide or move unexpectedly. Therefore, the material must be handled carefully.
- 18. Emergency stop.** Use the emergency stop button in case of any emergency.
- 19. Level machine.** Level the machine on a flat concrete surface by using a spirit level.
- 20. Overloading machine.** Do not exceed the rated capacity of the guillotine. Please refer to the manual for capacities.
- 21. Hearing protection and hazards.** Always wear hearing protection as noise generated from machine and workpiece can cause permanent hearing loss over time.
- 22. Call for help.** If at any time you experience difficulties, stop the machine and call your nearest branch service department for help.

PLANT SAFETY PROGRAM

NEW MACHINERY HAZARD IDENTIFICATION, ASSESSMENT & CONTROL

Power Operated Guillotine

Developed in Co-operation Between A.W.I.S.A and Australia Chamber of Manufactures
This program is based upon the Safe Work Australia, Code of Practice - Managing Risks of Plant in the Workplace (WHSA 2011 No10)

Item No.	Hazard Identification	Hazard Assessment	Risk Control Strategies <small>(Recommended for Purchase / Buyer / User)</small>
B	CRUSHING	LOW	Secure & support work material on table.
C	CUTTING, STABBING, PUNCTURING	MEDIUM	Wear gloves to prevent cuts from sharp material offcuts.
D	SHEARING	MEDIUM	Hands should be kept clear of moving parts and blades. Isolate power to machine prior to any checks or maintenance. Ensure front blade guard is fitted securely. Do not adjust or clean until machine has fully stopped. Access to the rear of machine must be interlock or photoelectric guarded to prevent access when the machine is operating, (see workcover authority principles of machine guarding for guidelines).
F	STRIKING	MEDIUM	Wear safety glasses. Stand clear of falling offcuts. Ensure material hold downs are correctly adjusted. Ensure guards are secured properly.
H	ELECTRICAL	MEDIUM	Machine should be installed & checked by a Licensed Electrician. All electrical enclosures should only be opened with a tool that is not to be kept with the machine.
O	OTHER HAZARDS, NOISE.	LOW	Wear hearing protection as required.
Plant Safety Program to be read in conjunction with manufactures instructions			



www.machineryhouse.com.au



www.machineryhouse.co.nz

Authorised and signed by:
Safety officer:



Manager:

Revised Date: 12th March 2012

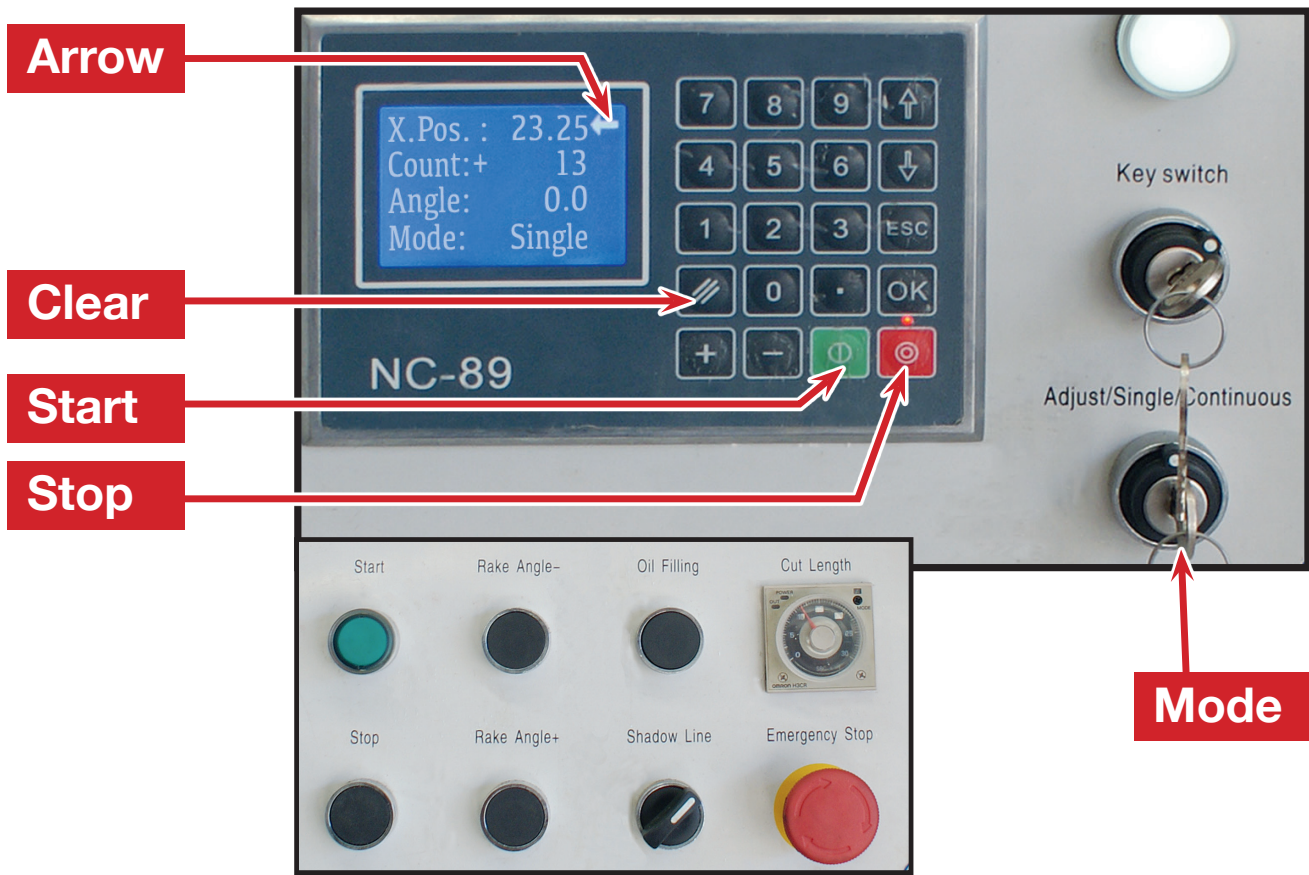



Variable Rake Guillotine NC89 Controller operation



X. Pos: *Back gauge position.*

Operation: Move Arrow to X Pos, clear number , enter desired value, press  and  start button. The back gauge will now go to the new entered position to within 0.5mm. Once back gauge has stopped searching use the manual handle for fine adjustment.

Count: *Number of cuts.*

Count can be cleared at any time by using clear  button, it will then count upwards with each cut. A set number of cuts can also be entered. **Operation:** Move Arrow to Count, clear the number , enter eg. 3 and press . After 3 cuts it will count down to 0 and the controller will stop cutting. You must now arrow down to Count and press  for counting upwards and enter any number for counting downwards.

Angle: *Rake angle of the blade.*

Rake angle range can be adjusted 0-2 for 8mm machines or 0-3 for 12mm machines. On 0 rake you can only cut thin material up to 0.8mm, when cutting thicker material you adjust blade to bigger rake angle. The larger the rake angle the easier it is for the guillotine to cut how ever thin strips of metal will deform during cutting. **Operation:** With pump running turn key switch to adjust and press Rake Angle – button to reduce the rake angle or press Rake Angle + button to increase the rake angle. The Angle figure on the screen will change as blade rake angle changes.

Mode: *Adjust/Single/Continues key switch*

Mode Adjust - Used for adjusting the rake angle or performing oil filling (refer to manual for oil filling).

Mode Single - Used to perform 1 cut at a time when foot pedal is pressed.

Mode Cont - Used to perform continuous cutting when foot pedal is pressed.

VARIABLE RAKE GUILLOTINE

Omrom E3Z Safety Sensor Operation & Alignment

Warning- Follow all setup instructions before starting hydraulic pump.

The safety circuit consists of a reset switch and two rear side guards, each having 3 sensors. Your machine may or may not have a RED warning light, if it does not see the NC89 for display (Reset Rear Guard). When the main power is switched on or the rear sensors have been tripped the safety circuit must be reset before the hydraulic pump can be started.

Warning Indication: The safety circuit has not been Reset.

RED warning light on



OR

NC89 Display



Reset Switch

Press to reset safety circuit and then press OK on NC89.

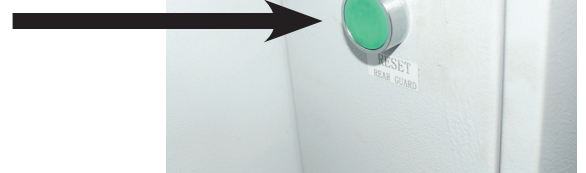

3 x Sensor Rear Guarding - Send & Receive Mounting Positions

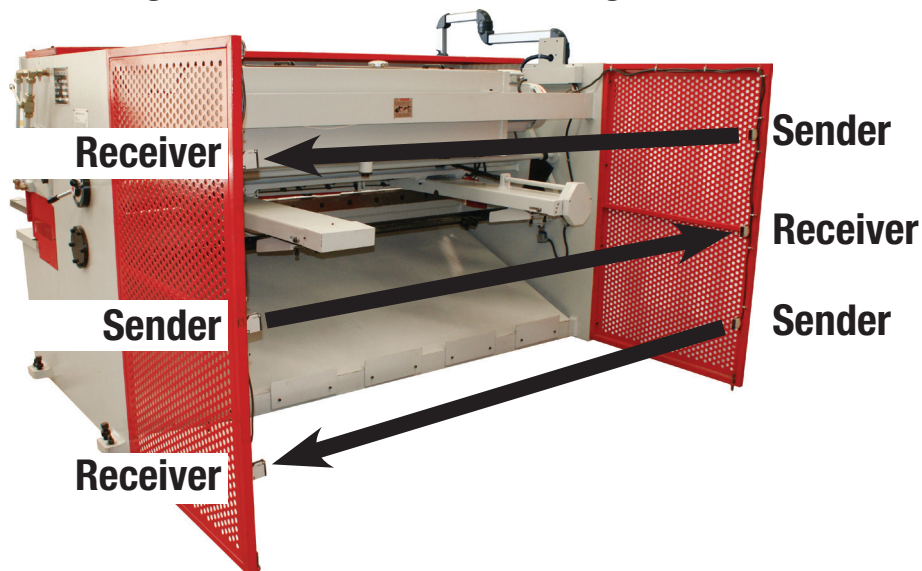

Identifying Sensors

Sender

The sender has one red light on top of the unit and one red light at the front. These two lights will be on all the time while the machine has power.

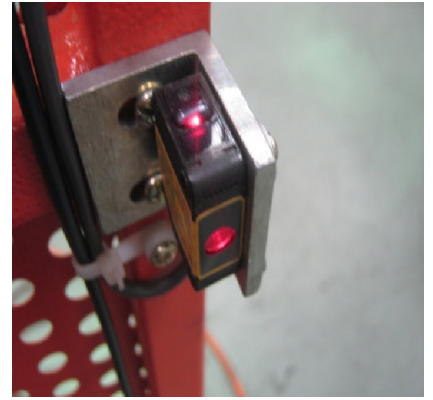

Receiver

The receiver has two lights on top of the unit. The receiver should have one green light on or a red and green light on when all the sensors have been aligned correctly.



Receiver - No lights on.
Indicates no power supply.



Receiver - Green light on.
Indicates power is on but not aligned.



Receiver - Red & Green lights on. Indicates power is on & aligned.

The receivers are wired in parallel so all of the receivers should show a green light to indicate power is on and ready for alignment.

When all 3 receivers are aligned correctly with their corresponding senders they will have both red and green lights on and then the safety circuit can be reset.

Alignment of Senders & Receivers

Ensure that the machine is level and all four leveling jacking bolts are correctly adjusted. Check the rear guards are bolted tight and adjust the stabilizing feet to ground level to support the guards.

The sensors are sensitive to alignment so try to align as accurately as possible. If the sender is only just aligned with the receiver, any vibration when cutting will stop the pump and the safety circuit will have to be reset again.

Loosen the sender screws and angle sender up until receiver loses alignment.

Angle sender down until receiver re-aligns and then loses alignment again.

Half way between these two positions is the most accurate alignment.

The sensors may also have to be angled sideways as well to get the best possible alignment. This may involve packing individual brackets or sensors.

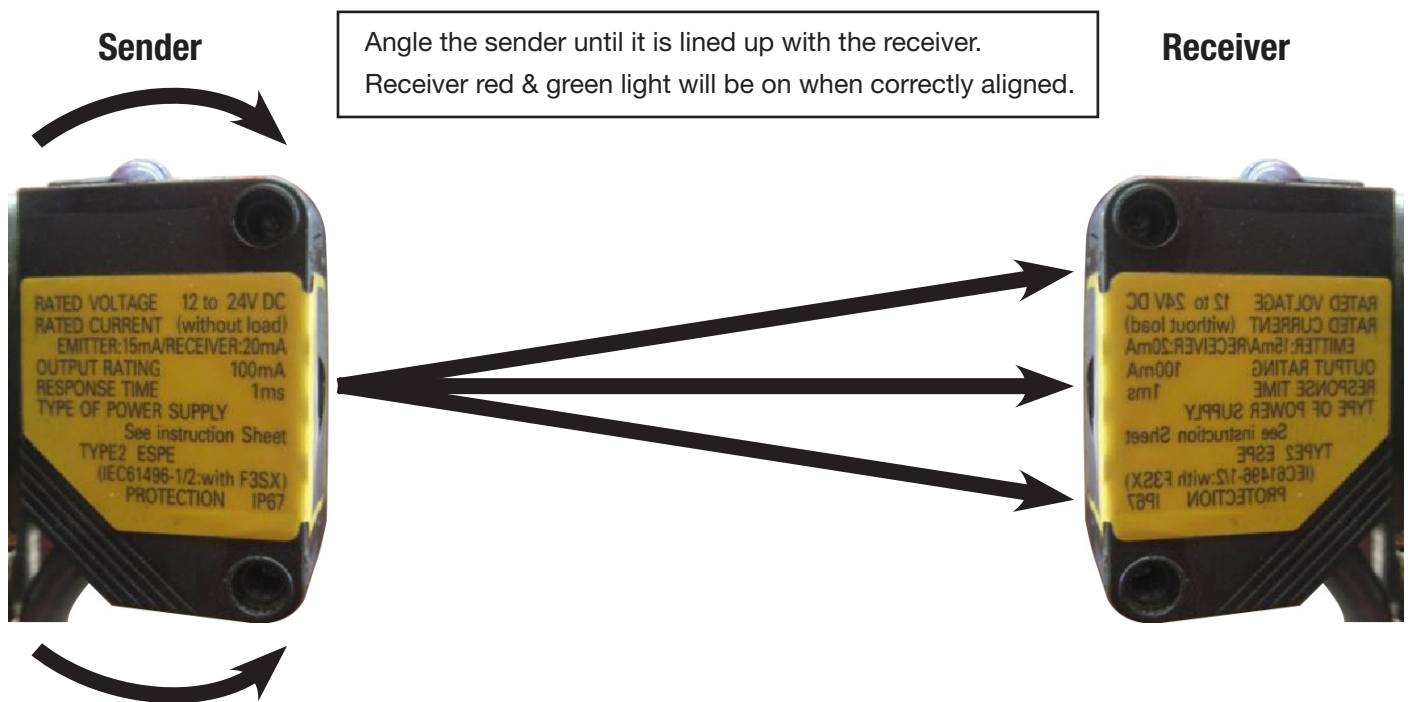

You can now reset the safety circuit & press OK on the NC89.

After a successful reset the NC89 screen should look like this. →



The Pump can now be started