

# INSTRUCTION MANUAL

**UB-100**  
**Bar Bender**  
**100 x 5mm**



**B043**

## Features and Specification of UB 70

### 1. Main Features:

Easy and precise operation.

Bending angle up to 120°.

Extremely high precision of bending within the bending range

Wide supporting face ensuring safe and reliable operation.

Bending angle of various radius by changing and/or turning around die plate.

Using bending eccentric block instead of bracket.

### 2. Specifications:

#### UB 70

Cold bending:

- flat steel 70×6; 60×8; 30×12mm
- square steel 16×16mm
- round steel  $\phi$  18mm
- └ angle steel 60×8mm

Hot bending:

- flat steel 70×15; 60×20mm
- square steel 30×30mm
- round steel  $\phi$  30mm
- └ angle steel 70×15mm

# UB 70

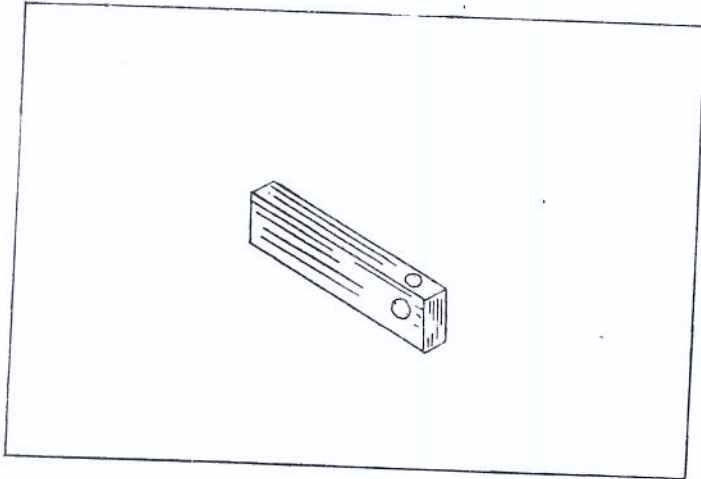

1. Limitlever

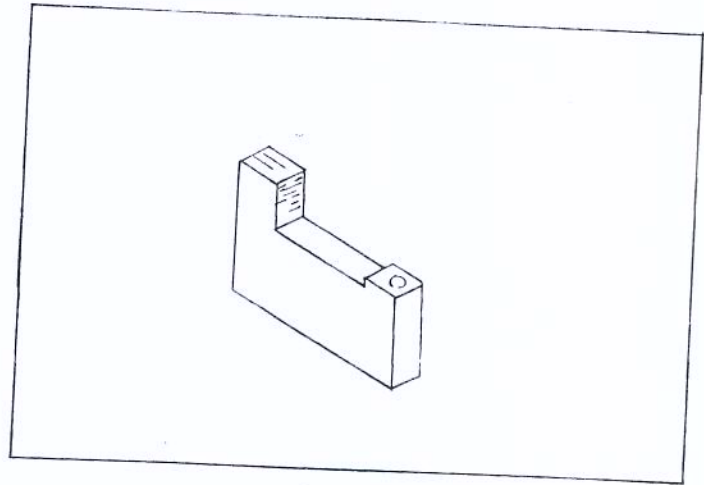

4. Bending die plate

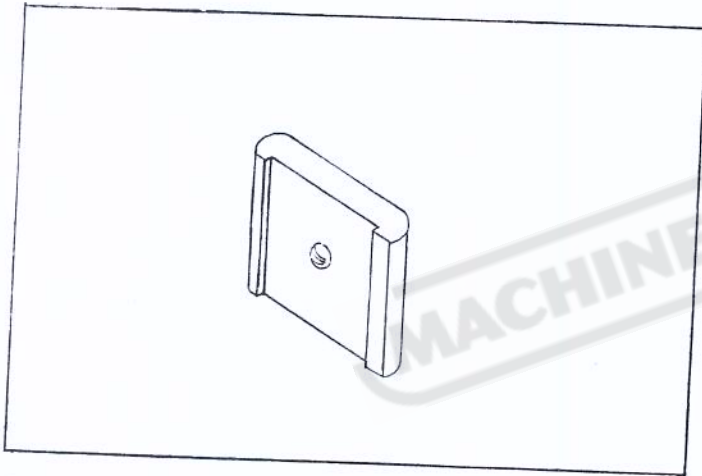

2. Die plate (fillet radius 10/15)

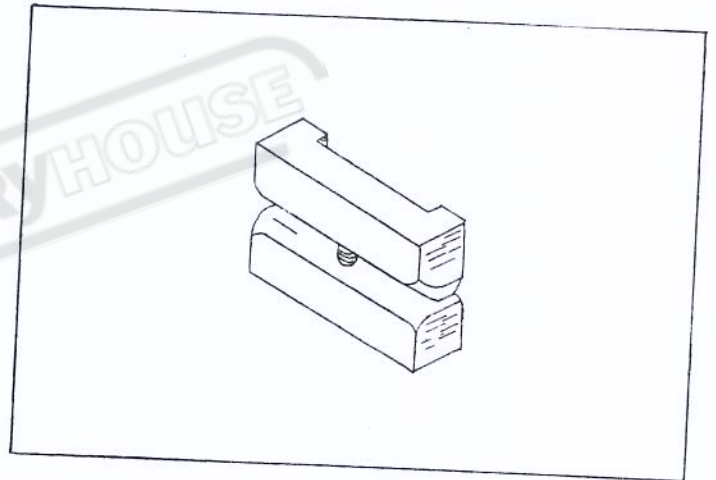

5. Die plate of diamond section

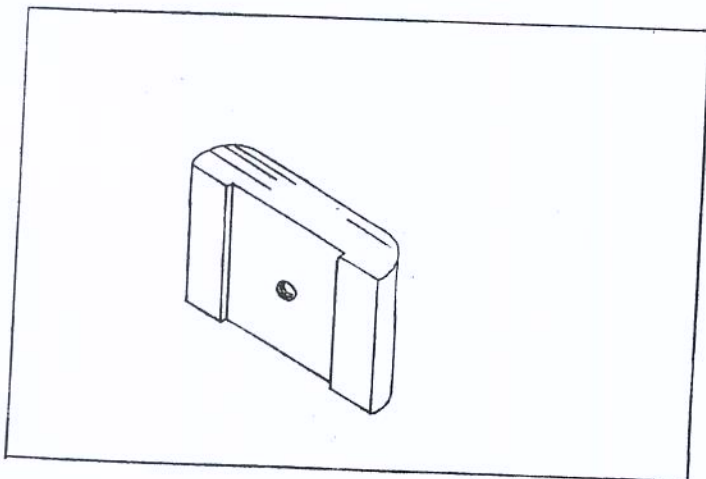

3. Die plate (fillet radius 20/25)

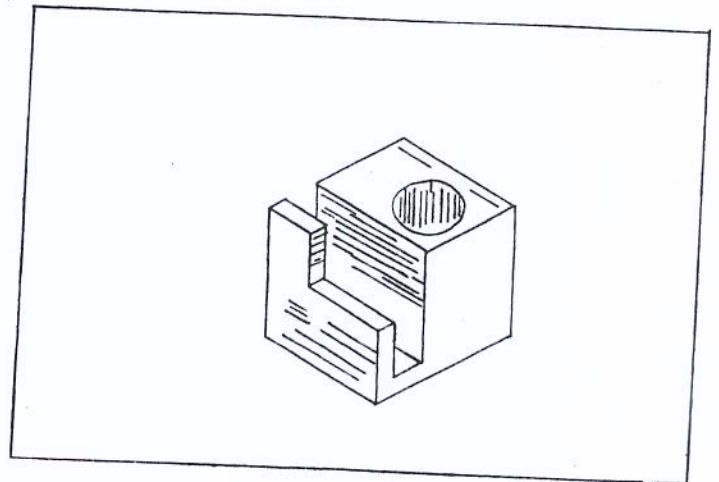

6. Bending eccentric seat